

TtecIR Interface Module Relays

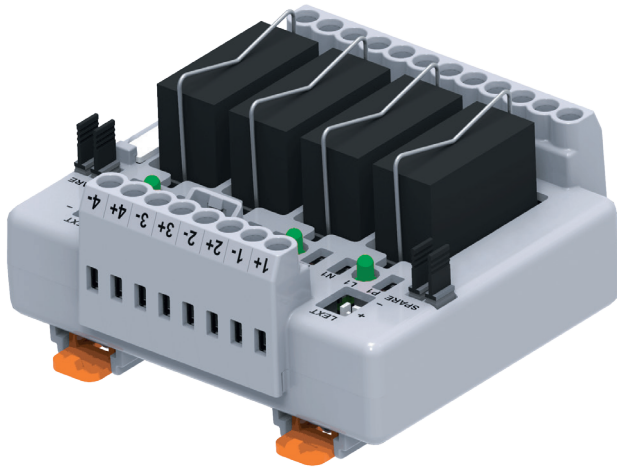

The TtecIR Interface Modules are a series of Electromechanical Relays which use 1N4007 Free-wheeling (Flyback) Diodes as a method of protecting the relay.

These next generation, compact, fully enclosed IP20 TtecIR Interface Modules are ideal for a wide range of industries, and their modular design allows configurations from 2 to 32 channels.

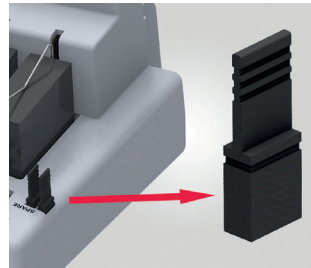

By default, these Interface Modules have pre-installed long tail jumpers, to enable quick creation of common negative circuits (common positive circuits can also be created).

When these jumpers are not in use, they can be stored in the 'SPARE' slots.

- Available in 1CO or 2CO
- Fully enclosed IP20 rated design
- Custom configurations up to 32 channels
- True 10A performance
- Ease of wire entry, clearly visible status indicators
- Pre-installed long tail jumpers (on the negative circuit by default)
- Industry first long-life laser marking for circuit identification

- Compact and secure mounting
- Additional all-axis marking provision
- High quality standards and approvals
- Easy to replace pluggable relays
- Free-wheeling (Flyback) Diode protection for DC coil
- IP20 Protection Class
- Variety of operating voltage

TtecIR Technical Specification

Number of Contacts	1 Changeover			2 Changeover		
Number of Channels	2	4	8	2	4	8
Rated Coil Voltage	24, 110, 230 VAC / 12, 24 VDC					
Relay Type	Pluggable or Soldered					
Supply Voltage Indication	3mm Green LED					
Ambient Operating Temperature	-20°C to 50°C					
Mounting Possibility	DIN 35 / DIN 35-15 Rail					
Housing Material	Polycarbonate					
Housing Colour	Grey 10A					
Relay Protection (DC Variant)	Using 1N4007 Free-wheeling (Flyback) Diode					
Cross Connection Possibility	Yes, by using the Long Tail Jumpers					
Protection Type	IP20					
Standard	IEC 60664					
Approvals						

TtecIR Ordering Scheme

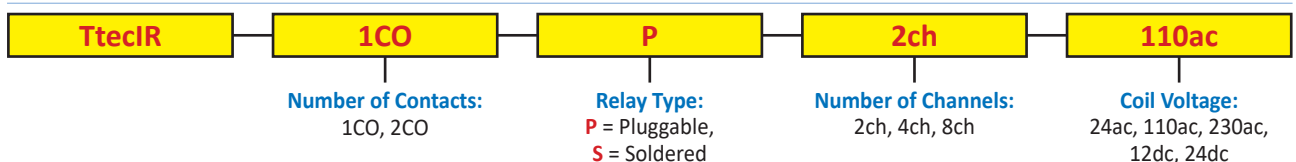

TteciR Technical Specification (Continued)

Rated Coil Voltage	24VAC	110VAC	230VAC	12VDC	24VDC
Rated Output Current/Channel	10A (1CO) / 5A (2CO)				
Coil Resistance	260 Ω	4,600 Ω	20,200 Ω	275 Ω	1,100 Ω
Rated Coil Current	46.5 mA	11 mA	5.5 mA	43.6 mA	21.8 mA
Must Operate Voltage	19.2 VAC	88 VAC	176 VAC	8.4 VDC	16.8 VDC
Must Release Voltage	7.2 VAC	33 VAC	66 VAC	1.8 VDC	2.4 VDC
Maximum Operating Voltage	26.4 VAC	121 VAC	242 VAC	13.2 VDC	31.2 VDC
Nominal Input Power	0.9 VA	0.9 VA	0.9 VA	530 mW	400 mW
Contact Type	SPDT - 1CO / DPDT - 2CO				
Contact Material	Ag-alloy (Cd free)				
Contact Resistance	30 mΩ max. / 50 mΩ max. (2CO-12VDC)				100 mΩ max.
Rated Contact Current (Resistive)	10A (1CO) / 5A (2CO)				12A (1CO) / 8A (2CO)
Load Voltage Range	250 VAC / 30 VDC				
Maximum Switching Voltage	380 VAC, 125 VDC				440 VAC, 300 VDC
Turn-Off Time	5 ms	10 ms		5 ms	
Turn-On Time	15 ms				
Max. Mechanical Operating Frequency	18,000 Operation/Hour				
Max. Electrical Operating Frequency	1,800 Operation/Hour				
Mechanical Life Expectancy	> 10,000,000 Operations			> 20,000,000 Operations	
Electrical Life Expectancy	> 100,000 Operations				> 50,000 Operations
Insulation Resistance	1000 mΩ				
Dielectric Strength	between Coil & Contact	5000 VAC			
	between Contact	1000 VAC			
Type of Connection	Screw Connection				
Minimum Wire Size	0.5 mm ² / 20 AWG				
Maximum Wire Size	2.5 mm ² / 12 AWG				
Wire Stripping Length	8 mm				
Applicable Torque	0.4 Nm / 3.5 lb-in				
Screw Size	M2.5				

TtecIR Dimensions

1 Changeover

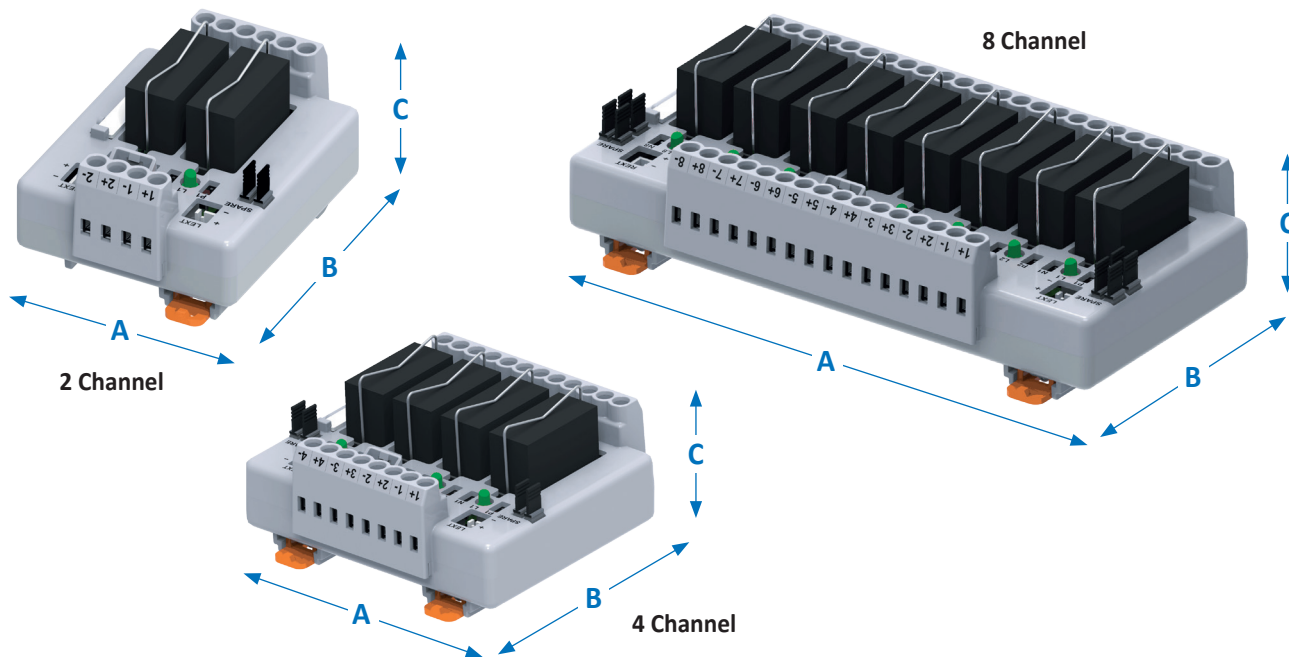

2 Changeover

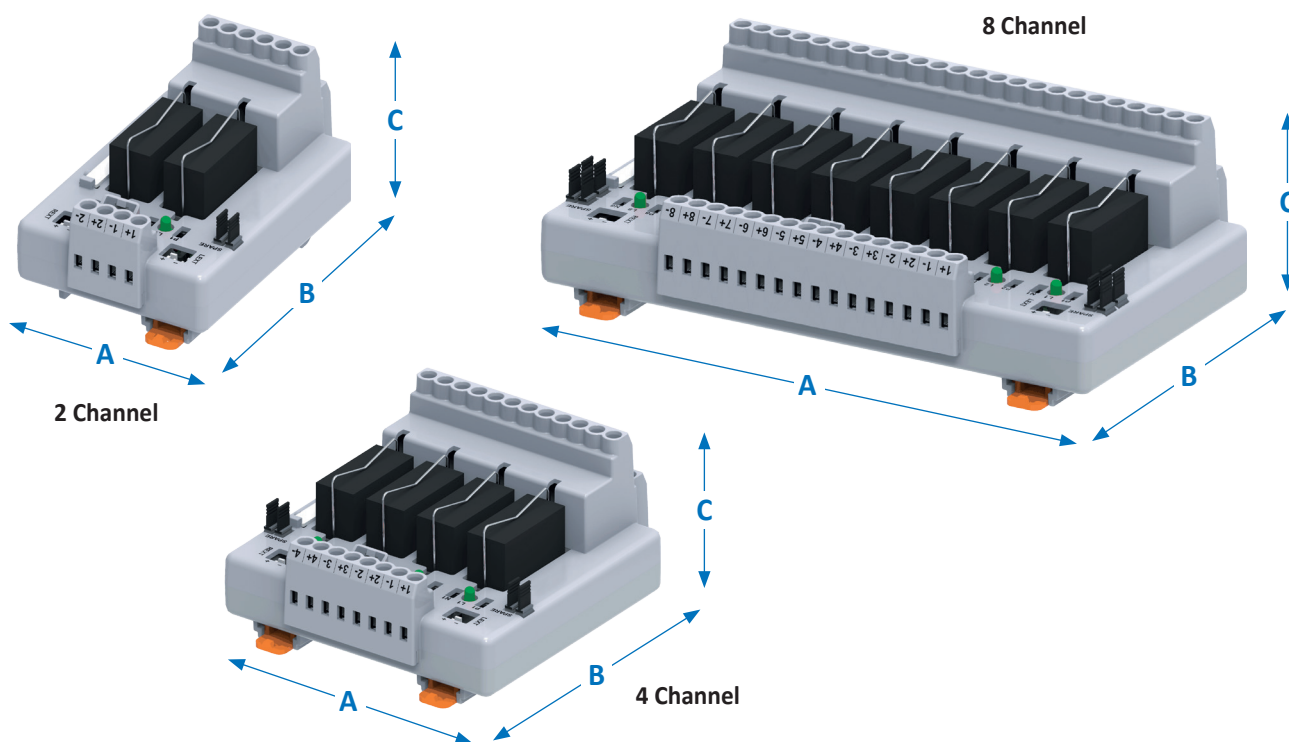

Number of Contacts	1CO			2CO		
Number of Channels	2	4	8	2	4	8
A	59 mm	85 mm	150 mm	61 mm	93 mm	162 mm
B	77 mm			98 mm		
C	57 mm			58 mm		

TtecIR 1CO Circuit Diagrams

AC Interface Modules

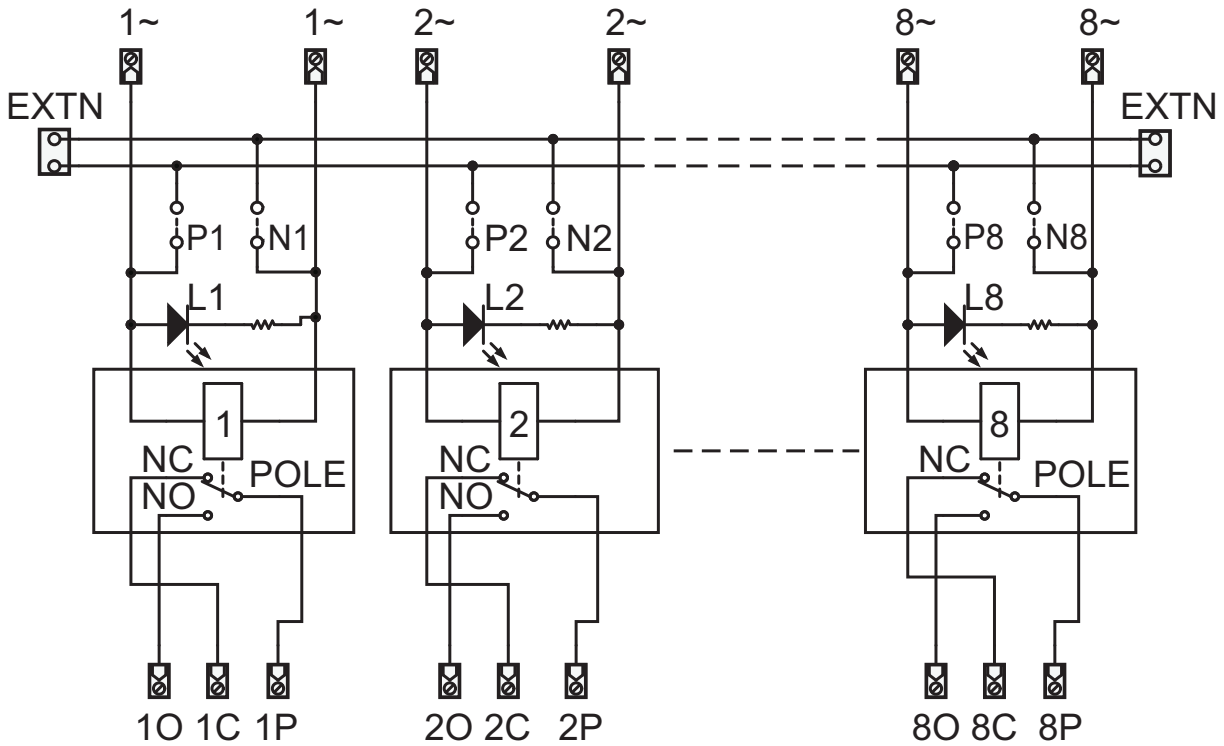

DC Interface Modules

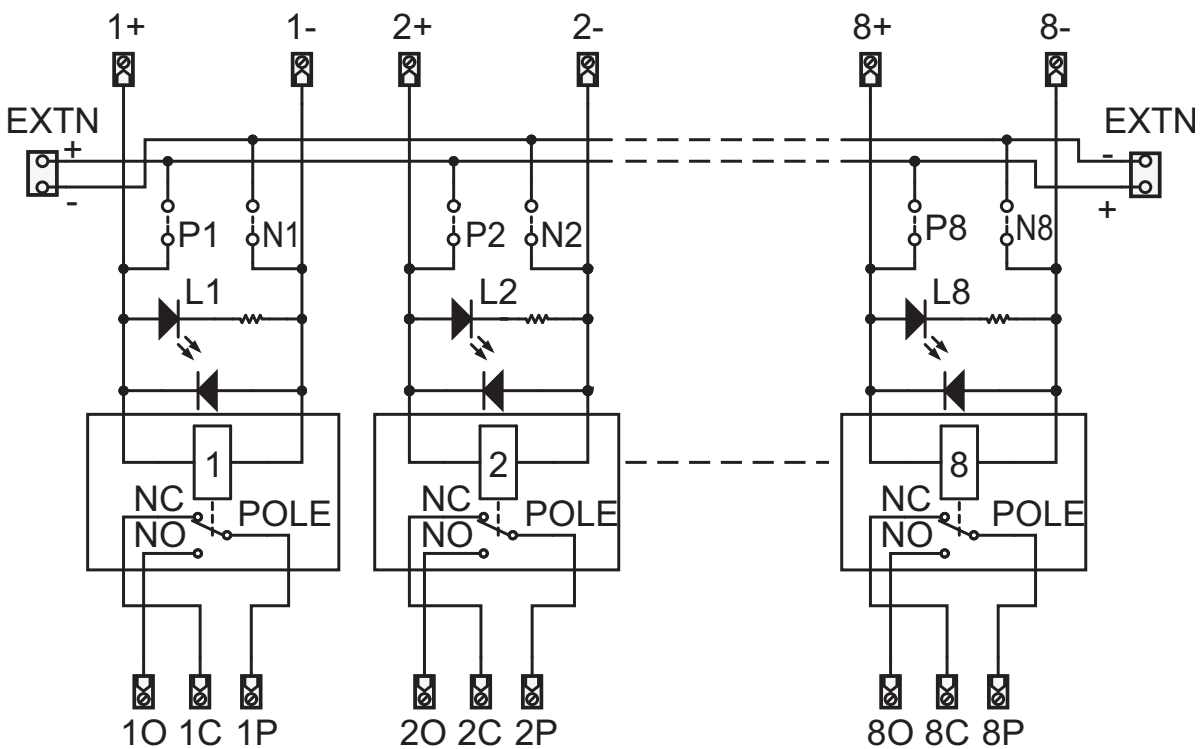

TtecIR 2CO Circuit Diagrams

AC Interface Modules

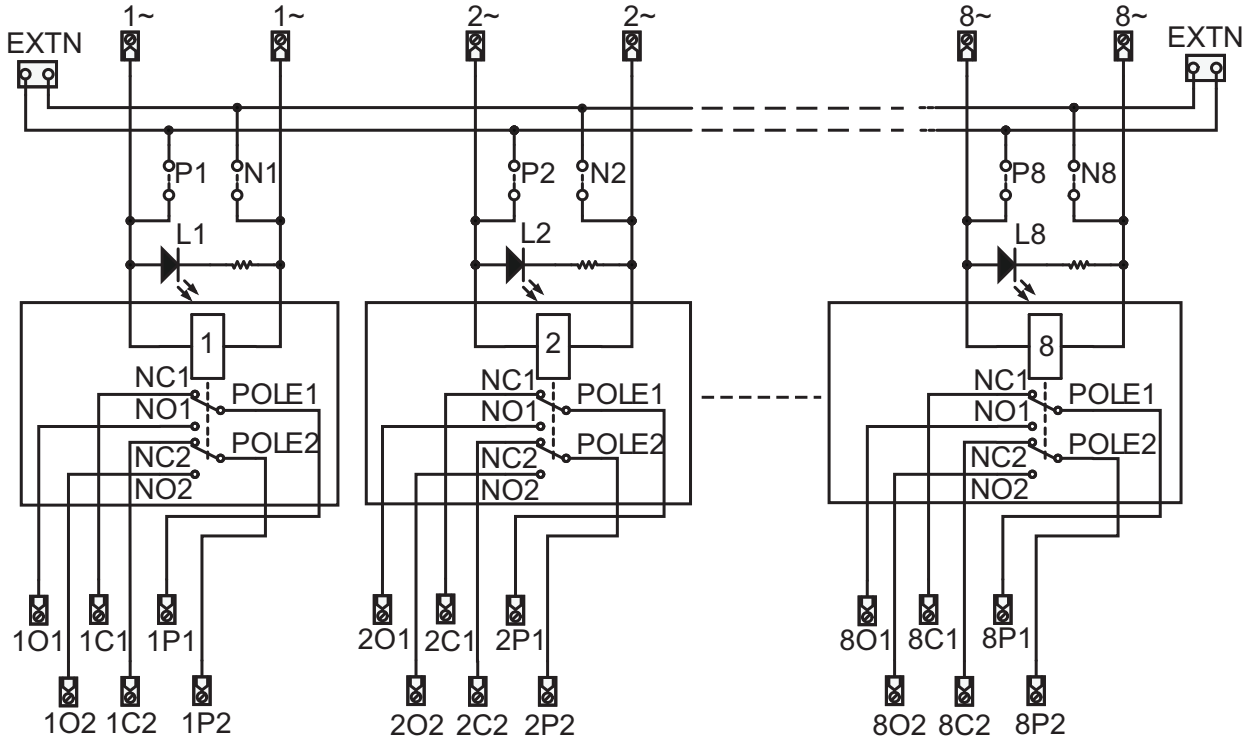

DC Interface Modules

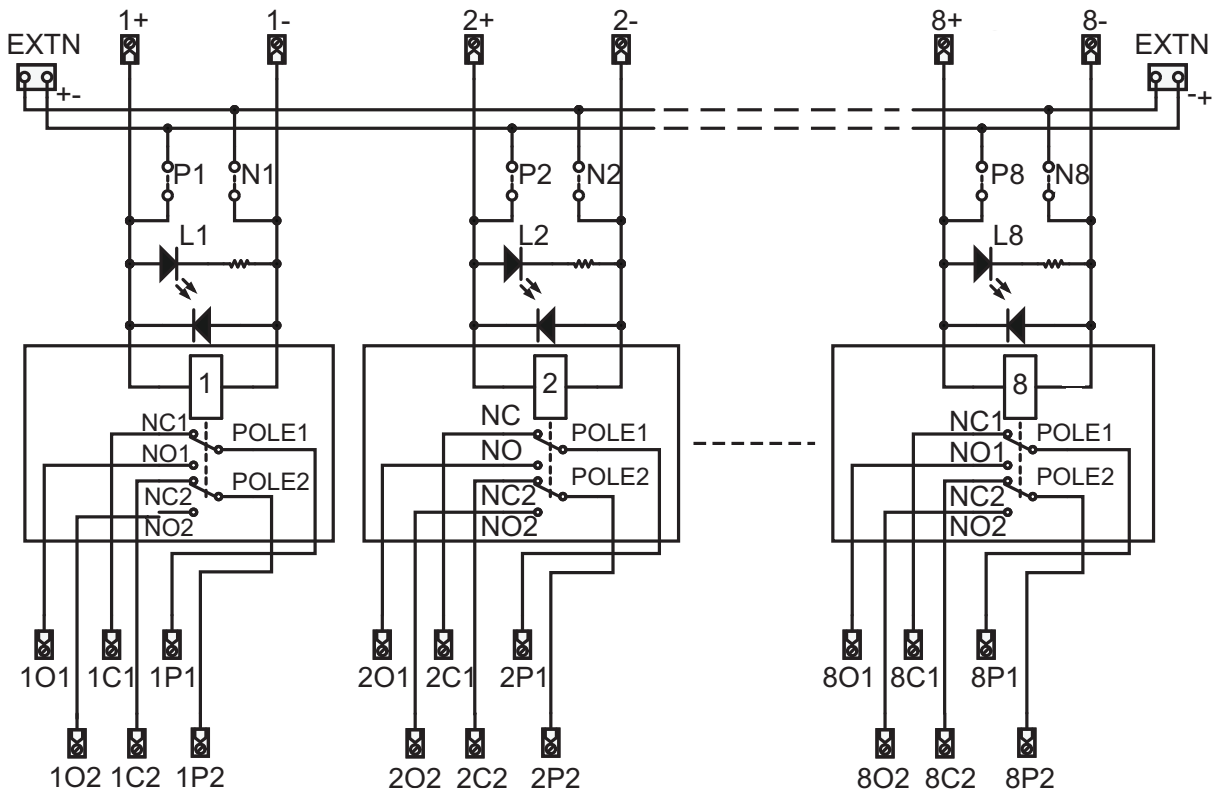

TtecIR Accessories

Extension Cable - TtecIMACC/IR/EXT

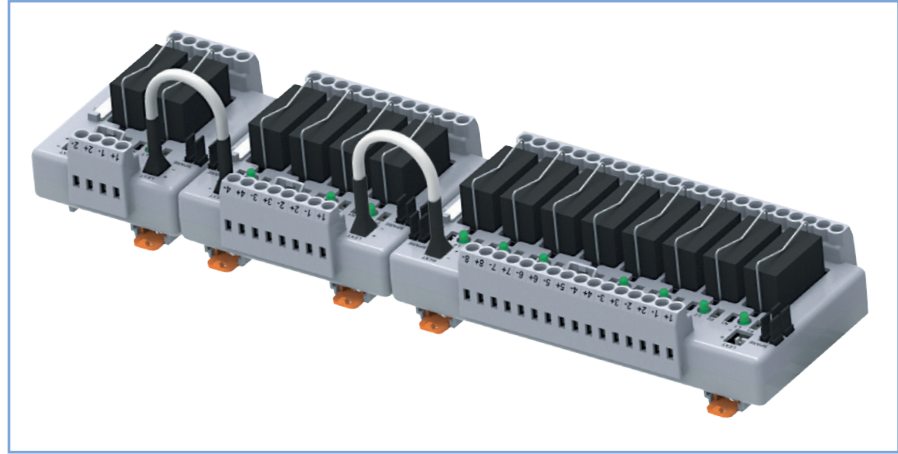

- Achieve multiple configurations for up to 32 channels, with the **TtecIMACC/IR/EXT** Extension Cable
- Accommodate last minute changes or circuit extensions without replacing the existing module

Marker Holder - TtecGMH8



- A large vertical, flush mounted area for marking is built into the TtecIR module
- With the **TtecGMH8** Marker Holder, raised horizontal markings can be achieved to provide all round visibility

Accessories	Order Codes
Extension Cable for connecting Modules together to achieve multiple configurations for up to 32 channels	TtecIMACC/IR/EXT
Marker Holder for raised horizontal markings for increased visibility	TtecGMH8